

HYDRAULIC VEHICLE POSITIONING JACK

CAPACITY: 1500LB PER UNIT

OPERATING INSTRUCTIONS

WARNING!

Read all the instructions and warning first before attempting to operate this Jack.

1. DO NOT operate Jack on inclined surfaces. Jack must be used on level surfaces only. Unanticipated motion will occur as soon as Jack lifts tire from surface.
2. DO NOT overload Jack's beyond the load rating (1500LBS per unit).
3. DO NOT start the vehicle's engine, or drive with Jack in use. Jacks are designed for hand maneuvering of vehicles only.
4. DO NOT use Jack to lift tires wider than 9 inches.
5. DO NOT attempt to push Jack over obstacles. They are designed to be used on level and reasonably smooth surfaces only.
6. After lifting, be sure to always lock the pin in place before operating. Pull the pin out after finishing work and then release the valve.

OPERATING INSTRUCTIONS

1. Place Jack on floor and press down on pedal to release pedal lock. Pull out the lock pin from frame.
2. Before operating, open release valve by turning hand wheel counter clock wise. Expand Jack by hand-wheel enough to place around tire and position so both rollers now contact the tire tread. To obtain the best control of jack while expanding around tire, place your left hand on top of the left side axle and your right hand at the center of the pedal. Close release valve by turning hand-wheel clock wise to a snug-tight position, Jack may now be used.
3. Install Jack so that the unit is parallel to the sidewall of the tire to be lifted. Leave approximately 3/4" of clearance between tire and jack. This is very important. If unit is misaligned, it is possible that the tire will be forced to hit the axle of the jack and not the rollers; this may damage the jack and void the warranty.
4. To lift tire, flip directional lever up and place foot on pedal depressing with smooth, even strokes. Cycle pedal until tire is lifted from surface one inch or less. After lifting, the lower the tire is to the ground the more stable the jack will be. After lifting, be sure to always lock the pin in place before operating, repeat process on the other tires and maneuver the vehicle as required.
5. To release Jack, pull the pin out from frame and open valve by turning hand-wheel counter-clock wise slowly. Jack may be removed when rollers disengage from tire.

PARTS LIST OF VEHICLE POSITIONING JACK

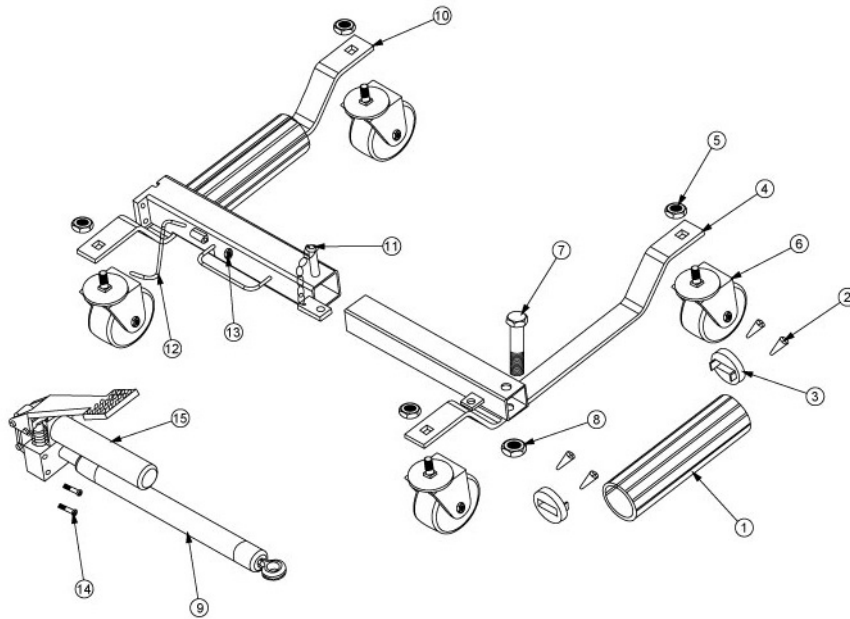

Ref#	Description	QTY	Ref#	Description	QTY
1	Roller	2	9	Ram Assembly	1
2	Raceway Lock Screw	8	10	Left Frame	1
3	Roller Raceway	4	11	Lock Pin With Chain	1
4	Right Frame	1	12	Hook	1
5	Lock Nut M12	4	13	Nut for Hook	1
6	4" Swivel Caster	4	14	Bolt M6x20	2
7	Bolt M14x80	1	15	Oil Tank	1
8	Nut M14	1			